



AVTECH ELECTROSYSTEMS LTD.

NANOSECOND WAVEFORM ELECTRONICS
SINCE 1975

P.O. BOX 265
OGDENSBURG, NY
U.S.A. 13669-0265
TEL: (315) 472-5270
FAX: (613) 226-2802

TEL: 1-800-265-6681
FAX: 1-800-561-1970

e-mail: info@avtechpulse.com
<http://www.avtechpulse.com/>

BOX 5120, LCD MERIVALE
OTTAWA, ONTARIO
CANADA K2C 3H4
TEL: (613) 226-5772
FAX: (613) 226-2802

INSTRUCTIONS

MODEL AV-1000-C

0 TO ± 10 VOLTS, 50 MHz
GENERAL PURPOSE PULSE GENERATOR

SERIAL NUMBER: _____

WARRANTY

Avtech Electrosystems Ltd. warrants products of its manufacture to be free from defects in material and workmanship under conditions of normal use. If, within one year after delivery to the original owner, and after prepaid return by the original owner, this Avtech product is found to be defective, Avtech shall at its option repair or replace said defective item. This warranty does not apply to units which have been disassembled, modified or subjected to conditions exceeding the applicable specifications or ratings. This warranty is the extent of the obligation assumed by Avtech with respect to this product and no other warranty or guarantee is either expressed or implied.

TECHNICAL SUPPORT

Phone: 613-226-5772 or 1-800-265-6681

Fax: 613-226-2802 or 1-800-561-1970

E-mail: info@avtechpulse.com

World Wide Web: <http://www.avtechpulse.com>

TABLE OF CONTENTS

WARRANTY	2
TECHNICAL SUPPORT	2
TABLE OF CONTENTS	3
INTRODUCTION	5
SPECIFICATIONS	6
EC DECLARATION OF CONFORMITY	7
INSTALLATION	8
VISUAL CHECK	8
POWER RATINGS	8
CONNECTION TO THE POWER SUPPLY	8
ENVIRONMENTAL CONDITIONS	8
FUSES	9
AC FUSE REPLACEMENT	9
DC FUSE REPLACEMENT	10
FUSE RATINGS	10
FRONT PANEL CONTROLS	11
REAR PANEL CONTROLS	15
GENERAL INFORMATION	16
BASIC PULSE CONTROL	16
TRIGGER MODES	18
GATING MODES	19
MINIMIZING WAVEFORM DISTORTIONS	20
USE 50Ω TRANSMISSION LINES	20
USE LOW-INDUCTANCE LOADS	20
WHEN DRIVING A 50 OHM LOAD	20
WHEN DRIVING HIGH IMPEDANCE LOADS	21
PROTECTING YOUR INSTRUMENT	22
TURN OFF INSTRUMENT WHEN NOT IN USE	22
AVOID SHORT CIRCUITS	22
USE THE LOWEST PRACTICAL AMPLITUDE RANGE	22
OPERATIONAL CHECK	23
TYPICAL WAVEFORMS	26

TYPICAL RISE/FALL TIMES.....	26
ADJUSTABLE RISE/FALL TIMES.....	26
50 MHz OPERATION.....	27
MECHANICAL INFORMATION.....	28
TOP COVER REMOVAL.....	28
RACK MOUNTING.....	28
ELECTROMAGNETIC INTERFERENCE.....	28
MAINTENANCE.....	29
REGULAR MAINTENANCE.....	29
CLEANING.....	29
REPAIR INSTRUCTIONS.....	30
BLOWN FUSES.....	30
DAMAGED MAIN OUTPUT.....	30
PERFORMANCE CHECK SHEET.....	31

Manual Reference: Z:\officefiles\instructword\av-1000\AV-1000-edd.sxw.

Last modified September 15, 2005.

Copyright © 2005 Avtech Electrosystems Ltd, All Rights Reserved.

INTRODUCTION

The Avtech AV-1000-C is a versatile, general-purpose, low-cost, 50 MHz laboratory pulse generator, useful everywhere from undergraduate university classrooms to the most advanced research and development laboratories. This pulse generator features variable pulse repetition frequency (PRF), delay, pulse width, rise and fall times, amplitude, and baseline.

The generator can be triggered internally or externally, or by the manual "Single Pulse" pushbutton. All trigger sources can be gated by a TTL-type pulse. The internal trigger is continuously variable from 1 Hz to 50 MHz. The delay and pulse width are variable up to 1 second. The amplitude and baseline offset are variable from 0 to $\pm 10V$. Rise and fall times are independently variable (within a given range) from less than 5ns to 1ms.

The main output has all of its characteristics variable, and is designed to drive 50 Ω loads. Four logic outputs (TTL, ECL, and their complements) have the same timing characteristics as the main output, but have non-adjustable rise and fall times, and have their amplitudes fixed at standard logic levels.

A synchronizing trigger output is also supplied, for triggering oscilloscopes and other test equipment (10 ns wide, +2V into 50 Ω).

This instrument is intended for use in research and development laboratories.

SPECIFICATIONS

Model:	AV-1000-C
PRF:	1 Hz to 50 MHz
Amplitude (to 50 Ohms):	Main output: 0 to ± 10 Volts (adjustable) TTL outputs (normal and inverted): low: 0 to +0.8V, high: +3 to +5V (fixed) ECL outputs (normal and inverted): low: -1.6V, high: -0.8V (fixed)
Pulse width:	10 ns to 1.0 sec
Rise time, fall time:	Main: 5 ns to 1 ms, TTL: 5 ns, ECL: 2 ns
Jitter (Sync out to pulse out):	$\leq \pm 25$ ps $\pm 0.01\%$ of sync delay
DC offset:	± 10 Volt range: 0 to ± 10 Volts. (Total output voltage can not exceed ± 10 V.) ± 1 , ± 5 Volt ranges: 0 to ± 5 Volts.
Source impedance (main output):	50 Ohms (± 1 and ± 5 Volt ranges) 2 Ohms (± 10 Volt range)
Polarity (main output):	Positive or negative (switch-selectable)
Duty cycle (max):	PRF ≤ 10 MHz: 80%, ≤ 40 MHz: 60%, 50 MHz: 40%
Waveform aberrations:	Overshoot, undershoot, and ringing are $< \pm 5\%$ at amplitudes of > 300 mV, with outputs terminated in 50 Ω .
Trigger required (Ext trig mode):	TTL levels (low: 0 to +0.8V, high: +3 to +5V), 4 ns or wider. 1k Ω input impedance.
Trigger required (Gate in):	0 to +0.8 V (or grounded): No output +3V to +5 V (or open): Normal output
Propagation delay:	< 75 ns (Ext trig in to main out, with sync delay set to minimum)
Sync delay:	± 25 ns to ± 1.0 sec (Sync out to main out)
Sync output:	+3 Volts, 10 ns, will drive 50 Ohm loads
Single pulse mode:	manual push-button
Signal connectors:	BNC
Power requirement:	100 - 240 Volt, 50 - 60 Hz
Dimensions (H x W x D):	100 mm x 430 mm x 375 mm (3.9" x 17" x 14.8")
Weight & chassis material:	4.5 kg (10 lbs), anodized aluminum, with blue plastic trim
Mounting & Temperature range:	Any, +5°C to +40°C

EC DECLARATION OF CONFORMITY

We

Avtech Electrosystems Ltd.
P.O. Box 5120, LCD Merivale
Ottawa, Ontario
Canada K2C 3H4

declare that this pulse generator meets the intent of Directive 89/336/EEC for Electromagnetic Compatibility. Compliance pertains to the following specifications as listed in the official Journal of the European Communities:

EN 50081-1 Emission

EN 50082-1 Immunity

and that this pulse generator meets the intent of the Low Voltage Directive 72/23/EEC as amended by 93/68/EEC. Compliance pertains to the following specifications as listed in the official Journal of the European Communities:

EN 61010-1:2001 Safety requirements for electrical equipment for measurement, control, and laboratory use



INSTALLATION

VISUAL CHECK

After unpacking the instrument mainframe and the transformer module, examine to ensure that they have not been damaged in shipment. Visually inspect all connectors, knobs, and handles. Confirm that a power cord and an instrumentation manual (this manual), are with the instrument. If the instrument has been damaged, file a claim immediately with the company that transported the instrument.

POWER RATINGS

This instrument is intended to operate from 100 - 240 V, 50 - 60 Hz.

The maximum power consumption is 57 Watts. Please see the "FUSES" section for information about the appropriate AC and DC fuses.

This instrument is an "Installation Category II" instrument, intended for operation from a normal single-phase supply.

CONNECTION TO THE POWER SUPPLY

An IEC-320 three-pronged recessed male socket is provided on the back panel for AC power connection to the instrument. One end of the detachable power cord that is supplied with the instrument plugs into this socket. The other end of the detachable power cord plugs into the local mains supply. Use only the cable supplied with the instrument. The mains supply must be earthed, and the cable used to connect the instrument to the mains supply must provide an earth connection. (The supplied cable does this.)

ENVIRONMENTAL CONDITIONS

This instrument is intended for use under the following conditions:

- a) indoor use;
- b) altitude up to 2 000 m;
- c) temperature 5 °C to 40 °C;
- d) maximum relative humidity 80 % for temperatures up to 31 °C decreasing linearly to 50 % relative humidity at 40 °C;
- e) Mains supply voltage fluctuations up to ± 10 % of the nominal voltage;
- f) no pollution or only dry, non-conductive pollution.

FUSES

This instrument contains four fuses. All are accessible from the rear-panel. Two protect the AC prime power input, and two protect the internal DC power supplies. The locations of the fuses on the rear panel are shown in the figure below:

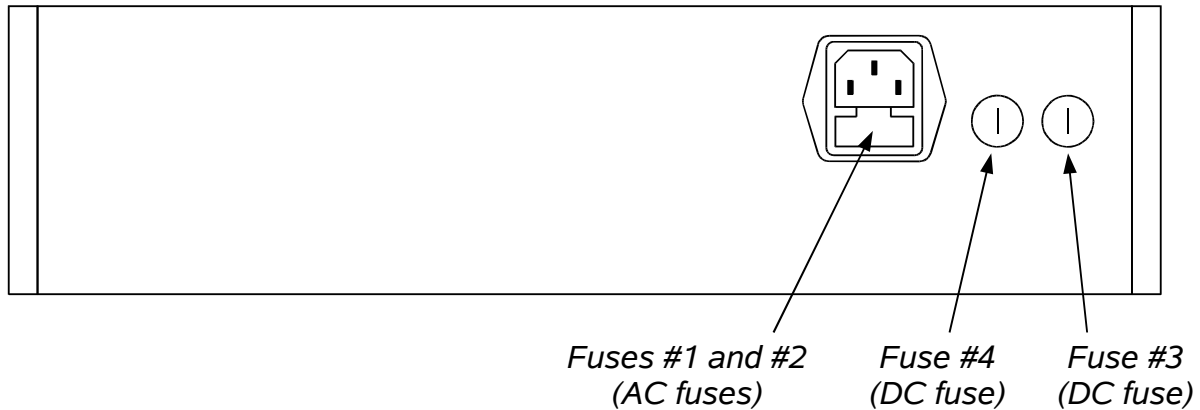

AC FUSE REPLACEMENT

To physically access the AC fuses, the power cord must be detached from the rear panel of the instrument. The fuse drawer may then be extracted using a small flat-head screwdriver, as shown below:

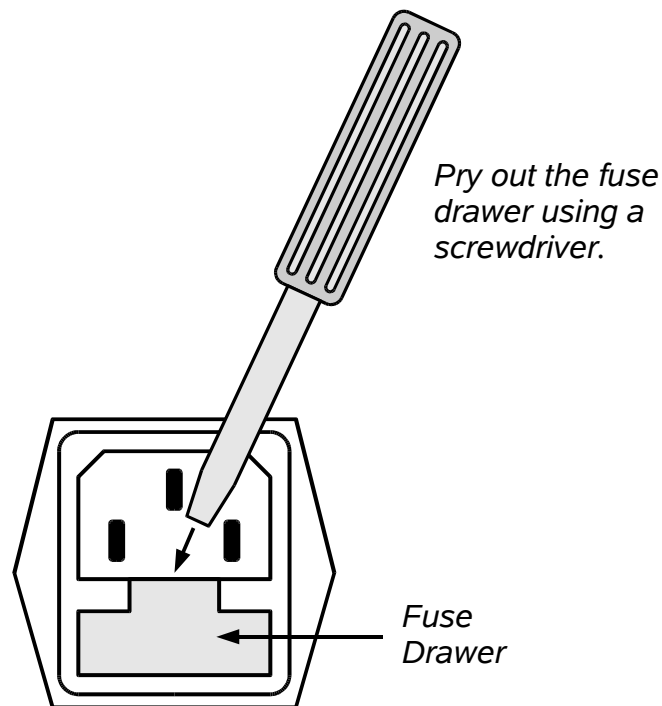

DC FUSE REPLACEMENT

The DC fuses may be replaced by inserting the tip of a flat-head screwdriver into the fuse holder slot, and rotating the slot counter-clockwise. The fuse and its carrier will then pop out.

FUSE RATINGS

The following table lists the required fuses:

Fuses	Nominal Mains Voltage	Rating	Case Size	Manufacturer's Part Number (Wickmann)	Distributor's Part Number (Digi-Key)
#1, #2 (AC)	100-240V	0.5A, 250V, Time-Delay	5×20 mm	1950500000	WK5041-ND
#3 (DC)	N/A	1.0A, 250V, Time-Delay	5×20 mm	1951100000	WK5048-ND
#4 (DC)	N/A	Not used. A spare 1.0A fuse is installed here.			

The fuse manufacturer is Wickmann (<http://www.wickmann.com/>).

Replacement fuses may be easily obtained from Digi-Key (<http://www.digikey.com/>) and other distributors.

FRONT PANEL CONTROLS

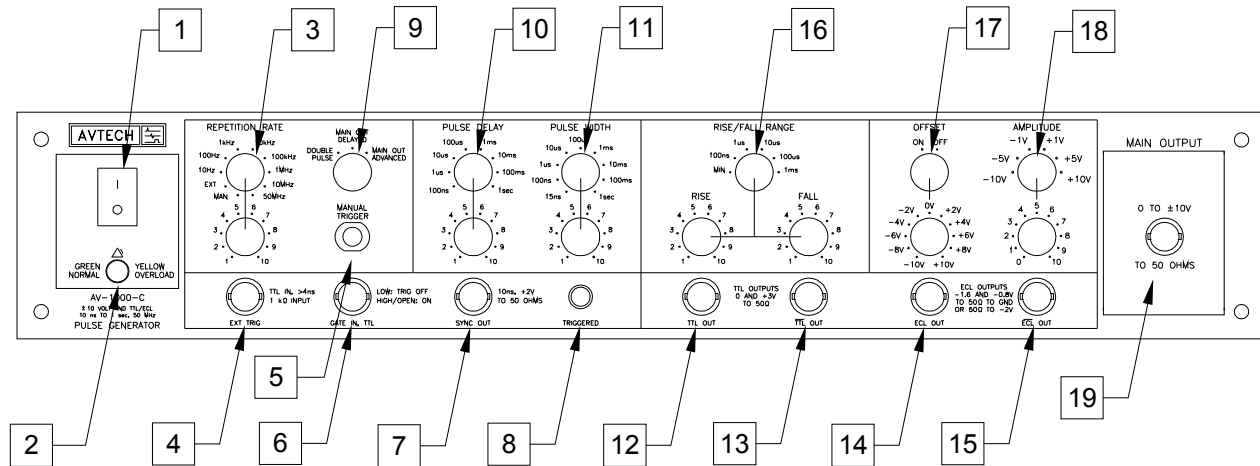

1. **POWER Switch.** This is the main power switch. When turning the instrument on, there may be a delay of several seconds before the instrument appears to respond.
2. **OVERLOAD Indicator.** When the instrument is powered, this indicator is normally green, indicating normal operation. If this indicator is yellow, an internal automatic overload protection circuit has been tripped. If the unit is overloaded (by operating at an exceedingly high duty cycle or by operating into a very low impedance), the protective circuit will disable the output of the instrument and turn the indicator light yellow. The light will stay yellow (i.e. output disabled) for about 5 seconds after which the instrument will attempt to re-enable the output (i.e. light green) for about 1 second. If the overload condition persists, the output will be disabled again (i.e. light yellow) for another 5 seconds. If the overload condition has been removed, the instrument will resume normal operation.

This overload indicator may flash yellow briefly at start-up. This is not a cause for concern.

3. **REPETITION RATE Controls.** This switch sets the triggering mode for the instrument.

In the “MAN” position, the instrument is triggered by the “Manual Trigger” pushbutton (item 5).

In the “EXT” position, the instrument is triggered by externally-generated TTL-level (0 and 3-5V logic levels) pulses on the “EXT TRIG” input connector (item 4).

The remaining positions serve as decade-range controls for the internal oscillator, which triggers the instrument in these positions. The vernier control immediately below the switch provides continuous adjustment of the frequency within each

decade range.

4. EXT TRIG Connector. When the REPETITION RATE switch (item 3) is set to the “EXT” position, a TTL-level pulse applied to this input will trigger the instrument. The instrument triggers on the rising edge of this input. The input impedance of this input is 1 k Ω . (Depending on the length of cable attached to this input, and the source driving it, it may be desirable to add a coaxial 50 Ohm terminator to this input to provide a proper transmission line termination. The Pasternack (www.pasternack.com) PE6008-50 BNC feed-thru 50 Ohm terminator is suggested for this purpose.)
5. MANUAL TRIGGER Pushbutton. When the REPETITION RATE switch (item 3) is set to the “MAN” position, the instrument is triggered by pressing this pushbutton. A single trigger event occurs for each press of the pushbutton.
6. GATE IN Connector. This TTL-level (i.e., 0 and 3-5V logic levels) input gates the trigger. If this input is unconnected or TTL-high (3 to 5V), the instrument will trigger normally. If this input is TTL-low (0 Volts), triggering is inhibited.
7. SYNC OUT Connector. This output generates a 10 ns wide TTL-level pulse for each trigger event. This output can be used to trigger an oscilloscope, or other test equipment.

The PULSE DELAY controls (item 10) and DELAY MODE switch (item 9) affect the operation of this output. When the DELAY MODE switch is in the “Main Out Delayed” position, the pulses on the main output (item 19) and the four logic outputs (items 12-15) are delayed relative to the SYNC OUT pulse by a time controlled by the PULSE DELAY controls (item 10).

When the DELAY MODE switch is in the “Main Out Advanced” position, the pulses on the main output (item 19) and the four logic outputs (items 12-15) are advanced relative to the SYNC OUT pulse by a time controlled by the PULSE DELAY controls (item 10).

When the DELAY MODE switch is in the “Double Pulse” position, the SYNC OUT pulse is approximately coincident with the first pulse of the pair of pulses on the main output.

For this output to operate correctly, the delay setting must be less than the period.

8. TRIGGERED Indicator. This indicator is lit when pulses are detected on the logic outputs (items 12 to 15), and it gives an indication that the timing parameters have been set properly and do not conflict.

If this indicator is not lit, it suggests that instrument is not triggering, or that the delay or pulse width settings exceed the pulse period.

9. DELAY MODE Switch. This switch determines the function of the PULSE DELAY controls (item 10). When this switch is set in the “DOUBLE PULSE” position, the main output (item 19) and the logic outputs (items 12-15) generate a pair of pulses in response to each trigger event. The DELAY controls determine the spacing between the first and second pulses in the pair. The SYNC OUT pulse is approximately coincident with the first pulse of the pair of pulses on the main output.

When the DELAY MODE switch is in the “Main Out Delayed” position, the pulses on the main output (item 19) and the four logic outputs (items 12-15) are delayed relative to the SYNC OUT pulse by a time controlled by the PULSE DELAY controls (item 10). The SYNC OUT pulse itself is generated after a minimal delay relative to the trigger source. (This is the most common mode of operation.)

When the DELAY MODE switch is in the “Main Out Advanced” position, the pulses on the main output (item 19) and the four logic outputs (items 12-15) are approximately coincident with the trigger event, and the SYNC output is delayed relative to the main output and logic outputs by a time controlled by the PULSE DELAY controls (item 10).

10. PULSE DELAY Controls. This decade range switch, and the vernier control immediately below, control the separation between the main and logic outputs (items 12-15 and 19) and the SYNC OUT output (item 7).
11. PULSE WIDTH Controls. This decade range switch, and the vernier control immediately below, control the pulse width of the main and logic outputs (items 12-15 and 19).
12. TTL OUT Connector. This output provides a TTL-level pulse (quiescent level: 0V, pulse level: 3-5V) whose triggering, delay, and pulse width are controlled by the front-panel controls. The amplitude and rise and fall times are fixed. This output will drive impedances of 50 Ohms or greater. To minimize distortion, this output should ideally be connected using 50 Ohm coaxial cabling, and terminated with a 50 Ohm load.
13. NOT-TTL OUT Connector. This output provides an inverted TTL-level pulse (quiescent level: 3-5V, pulse level: 0V) whose triggering, delay, and pulse width are controlled by the front-panel controls. This output is the logical complement of the TTL OUT output (item 12). This output will drive impedances of 50 Ohms or greater. To minimize distortion, this output should ideally be connected using 50 Ohm coaxial cabling, and terminated with a 50 Ohm load.
14. ECL OUT Connector. This output provides an ECL-level pulse (quiescent level: -1.6V, pulse level: -0.8V) whose triggering, delay, and pulse width are controlled by the front-panel controls. The amplitude and rise and fall times are fixed. This output will drive a load of 50 Ohms or greater, connected to ground or to -2V. To minimize distortion, this output should ideally be connected using 50 Ohm coaxial cabling, and terminated with a 50 Ohm load.

15. NOT-ECL OUT Connector. This output provides an inverted ECL-level pulse (quiescent level: -0.8V, pulse level: -1.6V) whose triggering, delay, and pulse width are controlled by the front-panel controls. This output is the logical complement of the ECL OUT output (item 14). This output will drive a load of 50 Ohms or greater, connected to ground or to -2V. To minimize distortion, this output should ideally be connected using 50 Ohm coaxial cabling, and terminated with a 50 Ohm load.
16. RISE/FALL TIME Controls. These controls determine the rise and fall time of the pulse on the main output (item 19). The rise and fall time vernier controls may be independently adjusted, but the decade range switch is common to both.
17. OFFSET Controls. When the OFFSET ON/OFF switch is set to "ON", the dial immediately below the switch controls the baseline of the main output. The offset may be varied between -10 and +10V when operating in the +10 or -10V amplitude ranges. (The maximum offset is proportionately less in the other amplitude ranges.) The offset feature may be disabled by setting the OFFSET ON/OFF switch to "OFF". The baseline offset is then fixed at zero Volts.
18. AMPLITUDE Controls. This range switch and vernier dial control the amplitude of the main output (item 19).

When the amplitude range is +10V or -10V, the output impedance is low (approximately 2 Ohms). This range provides for the highest amplitude, but no backmatching is provided, which may result in waveform distortion if the load is not 50 Ohms.

In the ± 1 and ± 5 V ranges, the output impedance is 50 Ohms. This provides backmatching for 50 Ohm transmission lines, which minimizes waveform distortions.

The best performance will be obtained when the lowest amplitude range consistent with the desired amplitude is used.

19. MAIN OUTPUT Connector. This is the main output. The amplitude and offset may be varied between -10V and +10V. The total output cannot exceed ± 10 V.

REAR PANEL CONTROLS

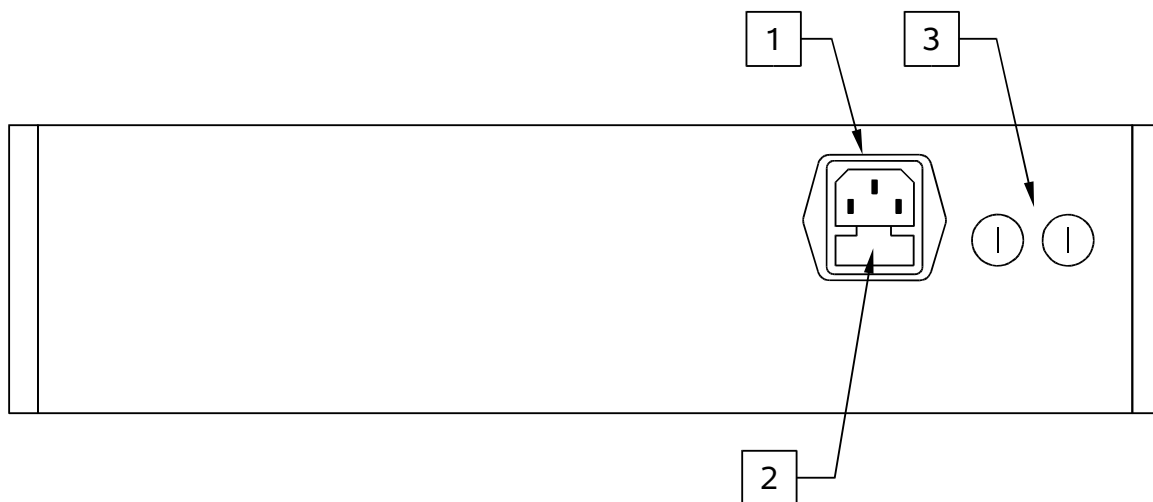

1. AC POWER INPUT. An IEC-320 C14 three-pronged recessed male socket is provided on the back panel for AC power connection to the instrument. One end of the detachable power cord that is supplied with the instrument plugs into this socket.
2. AC FUSE DRAWER. The two fuses that protect the AC input are located in this drawer. Please see the “FUSES” section of this manual for more information.
3. DC FUSES. These two fuses protect the internal DC power supplies. Please see the “FUSES” sections of this manual for more information.

GENERAL INFORMATION

BASIC PULSE CONTROL

This instrument can be triggered by its own internal clock, by an external TTL trigger signal, or by the front-panel MANUAL TRIGGER pushbutton. In any case, six output channels respond to the trigger: MAIN OUTPUT, SYNC, TTL, NOT-TTL, ECL, and NOT-ECL. The MAIN OUTPUT channel is the signal that is normally applied to the load. Its amplitude and pulse width are variable. The SYNC pulse is a fixed-width TTL-level reference pulse used to trigger oscilloscopes or other measurement systems. When the delay is set to a positive value the SYNC pulse precedes the OUT pulse. When the delay is set to a negative value the SYNC pulse follows the OUT pulse.

The four logic outputs (TTL, NOT-TTL, ECL, and NOT-ECL) are approximately coincident with the main output, but have fixed amplitudes and rise and fall times. These pulses are illustrated below, assuming that internal triggering is used, and the delay mode is set to "MAIN OUT DELAYED":

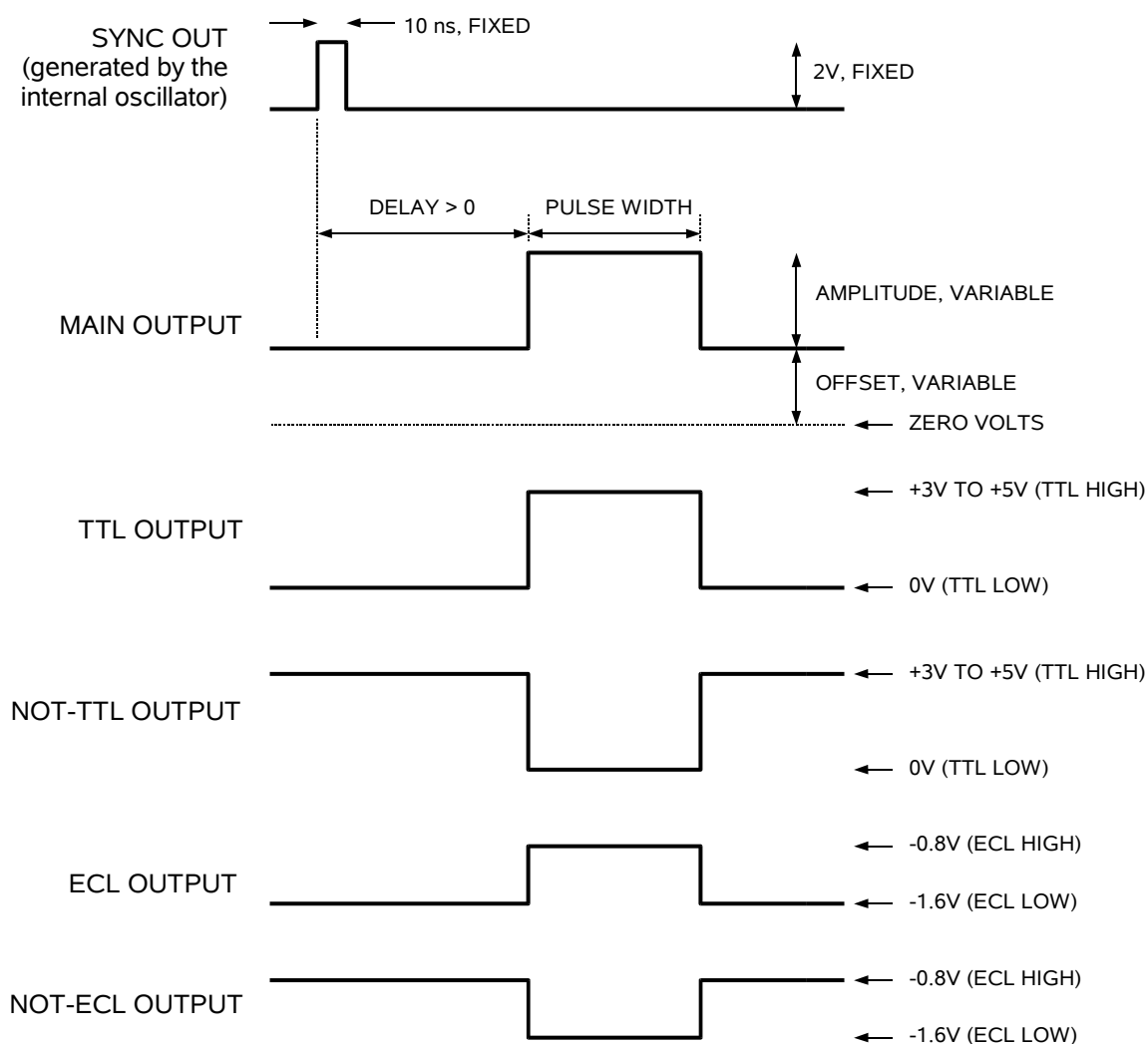

If the delay mode is set to “MAIN OUT ADVANCED”, the order of the SYNC and OUT pulses is reversed:

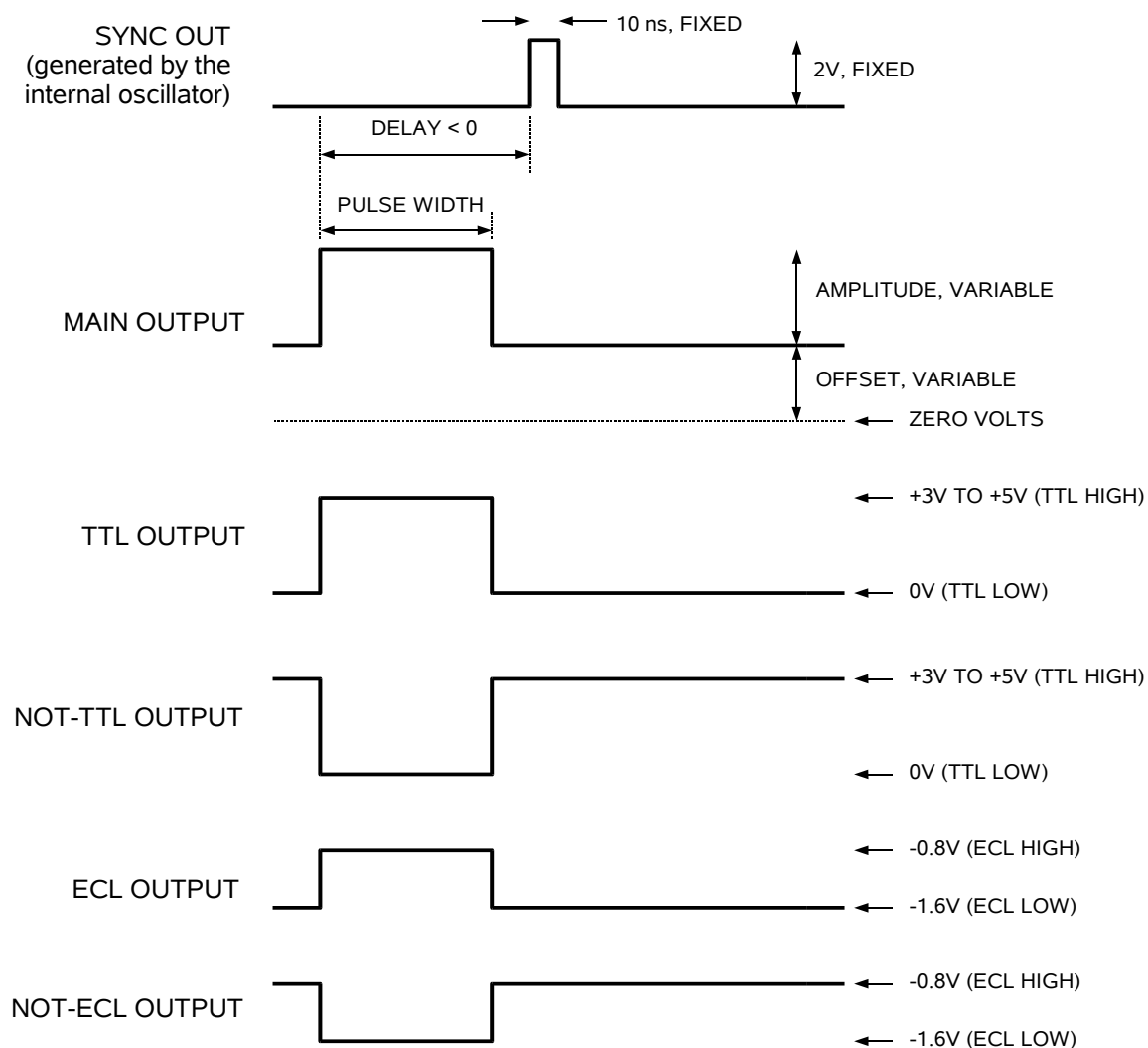

The next figure illustrates the relationship between the signals when an external TTL-level trigger is used (i.e., the REPETITION RATE switch is set to “EXT”), assuming that the delay mode is set to “MAIN OUT DELAYED”:

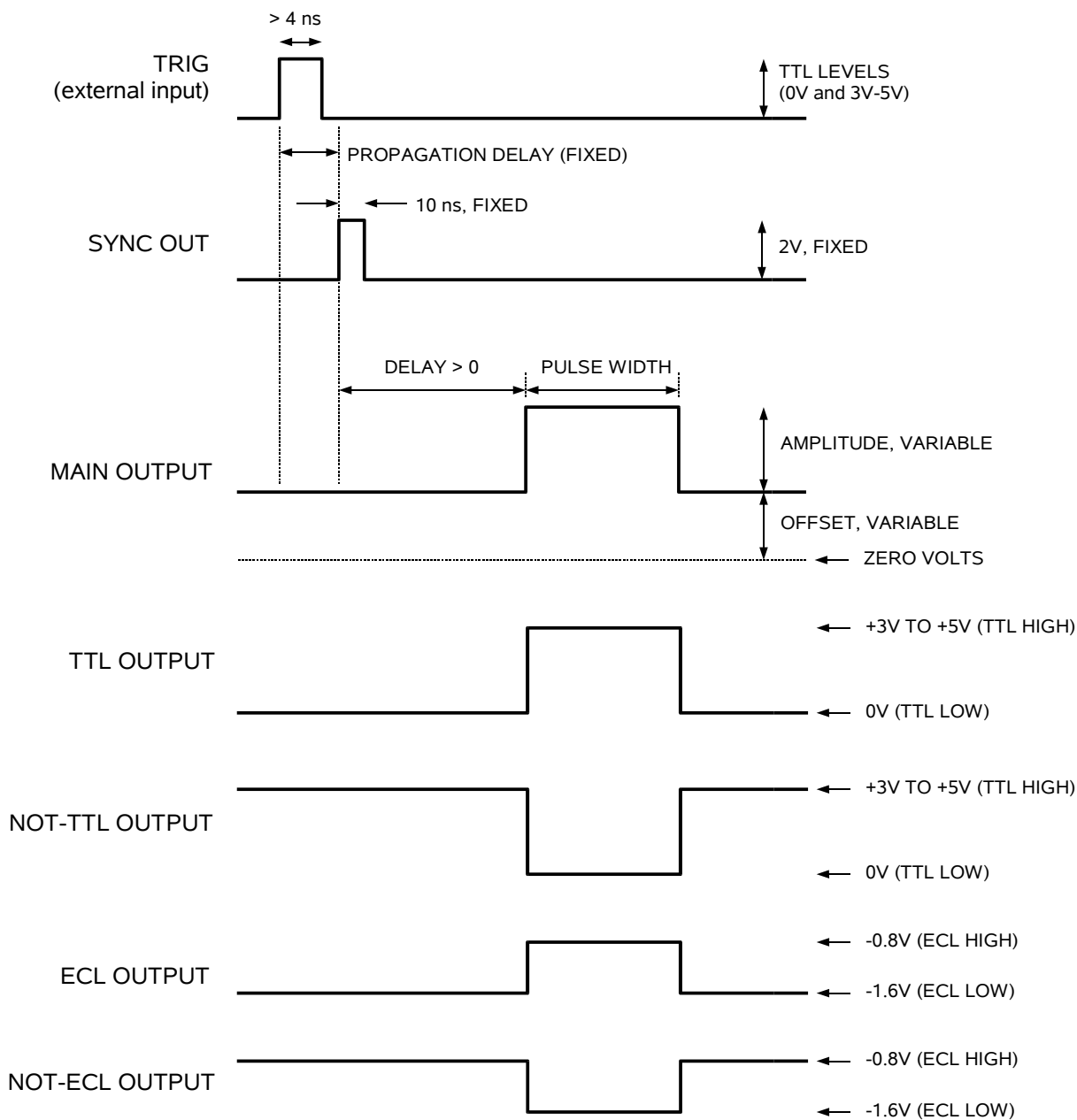

As before, if the delay mode is set to “MAIN OUT ADVANCED”, the order of the SYNC and OUT pulses is reversed.

TRIGGER MODES

This instrument has three trigger modes:

- Internal Trigger: the instrument controls the trigger frequency, and generates the clock internally. This mode is enabled by setting the REPETITION RATE switch to

one of the positions labeled with a frequency (i.e., 1kHz, 10 kHz, etc). The labeled frequency represents the upper end of that frequency range.

- External Trigger: the instrument is triggered by an external TTL-level clock on the EXT TRIG connector. This mode is enabled by setting the REPETITION RATE switch to the “EXT” position.
- Manual Trigger: the instrument is triggered by the front-panel “MANUAL TRIGGER” pushbutton. This mode is enabled by setting the REPETITION RATE switch to the “MAN” position.

GATING MODES

Triggering can be suppressed by a TTL-level signal on the GATE IN connector. If the GATE IN input is unconnected or TTL-high (3 to 5V), the instrument will trigger normally. If this input is TTL-low (0 Volts), triggering is inhibited.

MINIMIZING WAVEFORM DISTORTIONS

USE 50Ω TRANSMISSION LINES

Connect the load to the pulse generator with 50Ω transmission lines (e.g. RG-58 or RG-174 cable). If possible, use a 50Ω load. If the actual device under test has a high impedance, consider adding a 50Ω termination in parallel with the load to properly terminate the transmission line.

USE LOW-INDUCTANCE LOADS

Lenz's Law predicts that for an inductive voltage spike will be generated when the current through an inductance changes. Specifically, $V_{\text{SPIKE}} = L \times dI_{\text{LOAD}}/dt$, where L is the inductance, I_{LOAD} is the load current change, and t is time. For this reason, it is important to keep any parasitic in the load low. This means keeping wiring short, and using low inductance components. In particular, wire-wound resistors should be avoided.

WHEN DRIVING A 50 OHM LOAD

The output impedance of the main output is either 2Ω (for the ±10V ranges) or 50Ω (for the ±1 and ±5V ranges). Whenever possible, the ranges with 50Ω output impedance should be used, because the 50Ω impedance provides backmatching for the coaxial cable.

This concept is illustrated in the figure below. The ideal scenario, with the least waveform distortion due to transmission line reflections, occurs when both the output impedance and the load impedance are 50Ω. In this case, both ends of the coaxial cable transmission line are effectively terminated with 50Ω.

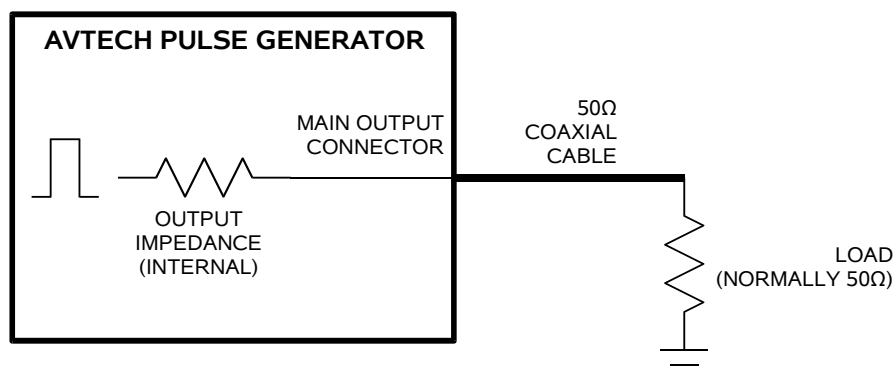

However, to obtain output amplitudes greater than ±5V, the ±10V ranges must be used, and the output impedance will be 2Ω. This is slightly less ideal, but good waveforms

will still be obtained since the transmission line is still properly terminated on one end (the load end) with 50Ω .

WHEN DRIVING HIGH IMPEDANCE LOADS

The ranges are labeled assuming operation into a 50 Ohm load. The $\pm 1\text{V}$ and $\pm 5\text{V}$ ranges will actually generate $\pm 2\text{V}$ and $\pm 10\text{V}$ respectively when driving a high impedance load ($\gg 50\Omega$). The $\pm 10\text{V}$ range capabilities are unchanged.

When driving a high impedance load (i.e., $R_L \gg 50\Omega$), using the $\pm 1\text{V}$ or $\pm 5\text{V}$ range amplitudes is recommended, since the 50Ω output impedance will provide a proper transmission line termination at the output end of the line, and the $\pm 5\text{V}$ range will actually provide the full $\pm 10\text{V}$ amplitude capability. The backmatching will minimize waveform ringing and transmission line reflections, without adversely affecting the pulse amplitude.

PROTECTING YOUR INSTRUMENT

TURN OFF INSTRUMENT WHEN NOT IN USE

The lifetime of the switching elements in the pulse generator module is proportional to the running time of the instrument. For this reason the prime power to the instrument should be turned off when the instrument is not in use. In the case of failure, the switching elements are easily replaced following the procedure described in a following section.

AVOID SHORT CIRCUITS

The output stage may be damaged if the output is shorted-circuited to ground or to a DC potential. Failures due to such short circuits are not covered by warranty!

USE THE LOWEST PRACTICAL AMPLITUDE RANGE

The output stage is less likely to fail under short-circuit conditions when the amplitude range is set to $\pm 1\text{V}$ or $\pm 5\text{V}$. It is more likely to fail in the $\pm 10\text{V}$ ranges. (The internal attenuators in the $\pm 1\text{V}$ and $\pm 5\text{V}$ ranges provide a measure of isolation between the output amplifier and the load.)

OPERATIONAL CHECK

This check is to confirm that the instrument is fully functional. In all tests, use 50 Ω cable with female BNC connectors on each end. Set the controls to the following values:

REPETITION RATE RANGE Switch: 1 MHz

REPETITION RATE Vernier: fully clockwise (maximum)

PULSE DELAY Switch: 100ns

PULSE DELAY Vernier: fully counter-clockwise (minimum)

PULSE WIDTH Switch: 100ns

PULSE WIDTH Vernier: fully clockwise (maximum)

RISE/FALL RANGE Switch: MIN

RISE Vernier: fully counter-clockwise (minimum)

FALL Vernier: fully counter-clockwise (minimum)

OFFSET ON/OFF Switch: OFF

AMPLITUDE Switch: +10V

AMPLITUDE Vernier: fully clockwise (maximum)

As shown below, connect a 50 Ohm coaxial cable from the SYNC OUT connector to the TRIG input of an oscilloscope with a bandwidth of at least 200 MHz. Connect a low-inductance 50 Ohm, 2W resistor across the MAIN OUTPUT connector. (A BNC-to-banana post adapter may be used for this purpose. Keep the resistor leads as short as possible).

Set the oscilloscope to trigger externally. Then follow the instructions in the following table, and compare what is seen on the oscilloscope to what is described. Only approximate values are needed to confirm operation.

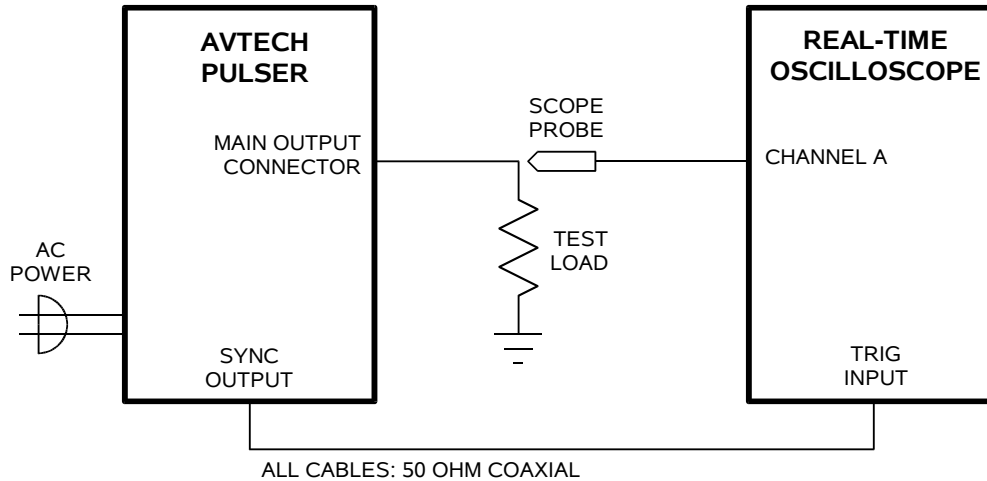

STEP	CONTROL	OPERATION	RESULTS
1	POWER	Push in (ON)	+10V pulses at the main output, with period 1 us, pulse width 100ns, < 10 ns rise and fall times.
2	REPETITION RATE VERNIER	Rotate to MIN (1), then to MAX (10)	Period rises to about 10 us, then falls to about 1 us.
3	DELAY VERNIER	Rotate to MAX, then to MIN	Pulses shift to the right on the oscilloscope by 100ns, then back.
4	PULSE WIDTH VERNIER	Rotate to MIN, then to MAX	Pulses become very narrow (about 10ns wide), then return to 100ns pulse width.
5	RISE VERNIER	Rotate to MAX, then to MIN	Rise time increases to 30ns, then decreases.
6	FALL VERNIER	Rotate to MAX, then to MIN	Fall time increases to 30ns, then decreases.
7	AMPLITUDE SWITCH	Switch to -10V, then to +10V	Pulses swing between 0 and -10V, then swing between 0 and +10V.
8	OFFSET ON/OFF SWITCH	Switch to ON	Pulses may shift up or down.
9	OFFSET VERNIER	Rotate to -10V	Pulses swing between -10V and 0V.
10	OFFSET ON/OFF SWITCH	Switch to OFF	Pulses swing between 0 and +10V.
11	AMPLITUDE SWITCH	Switch to +5V, then +1V, then back to +10V	Amplitude falls to +5V, then +1V, then rises back up to +10V.
12	TTL OUT	Remove cable from MAIN OUTPUT connector, place on TTL OUT connector.	Oscilloscope shows pulses swinging between 0V and +3V, with period 1 us, and pulse width 100ns.

13	ECL OUT	Remove cable, place on ECL OUT connector	Oscilloscope shows pulses swinging between -0.8V and -1.6V, with period 1 us, and pulse width 100ns.
14	NOT TTL OUT	Remove cable from ECL OUT connector, place on NOT TTL OUT connector	Oscilloscope shows inverted pulses swinging between 0V and 3V, with period 1 us, and low time 100ns.
15	NOT ECL OUT	Remove cable from NOT TTL OUT connector, place on NOT ECL OUT connector	Oscilloscope shows inverted pulses swinging between -0.8V and -1.6V, with period 1 us, and pulse width 100ns.

This completes the operational check.

TYPICAL WAVEFORMS

TYPICAL RISE/FALL TIMES

10 kHz repetition rate, 100 ns pulse width, +10V into a 50 Ohm load, with rise and fall times set to minimum:

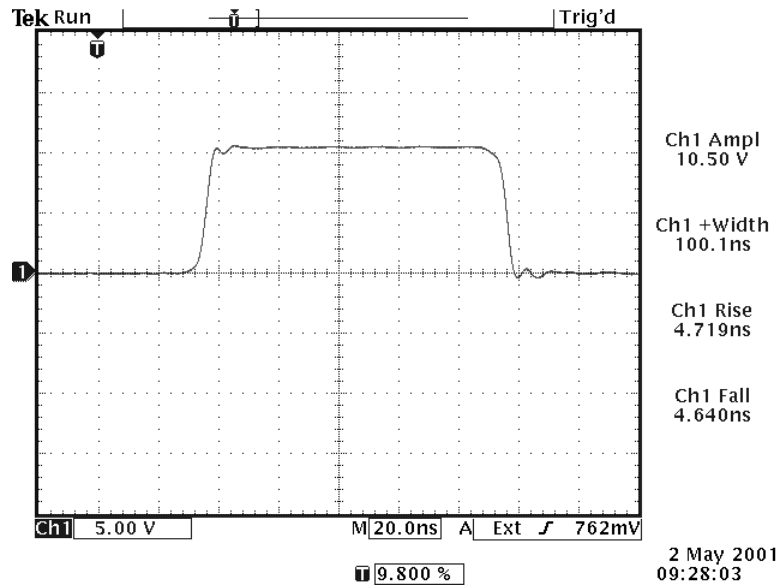

ADJUSTABLE RISE/FALL TIMES

10 kHz repetition rate, +10V into a 50 Ohm load, with rise/fall time range switch set to 1 us, and rise time vernier at minimum and fall time vernier at maximum:

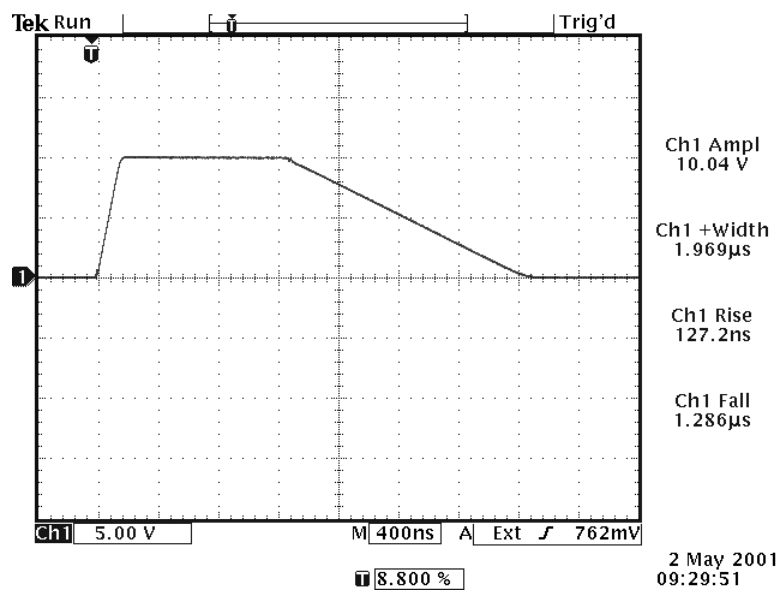

MECHANICAL INFORMATION

TOP COVER REMOVAL

If necessary, the interior of the instrument may be accessed by removing the four Phillips screws on the top panel. With the four screws removed, the top cover may be slid back (and off).

Always disconnect the power cord before opening the instrument.

There are no user-adjustable internal circuits. For repairs other than fuse replacement, please contact Avtech (info@avtechpulse.com) to arrange for the instrument to be returned to the factory for repair.



Caution: High voltages are present inside the instrument during normal operation. Do not operate the instrument with the cover removed.

RACK MOUNTING

A rack mounting kit is available. The -R5 rack mount kit may be installed after first removing the one Phillips screw on the side panel adjacent to the front handle.

ELECTROMAGNETIC INTERFERENCE

To prevent electromagnetic interference with other equipment, all used outputs should be connected to shielded 50Ω loads using shielded 50Ω coaxial cables. Unused outputs should be terminated with shielded 50Ω coaxial terminators or with shielded coaxial dust caps, to prevent unintentional electromagnetic radiation. All cords and cables should be less than 3m in length.

MAINTENANCE

REGULAR MAINTENANCE

This instrument does not require any regular maintenance.

On occasion, one or more of the four rear-panel fuses may require replacement. All fuses can be accessed from the rear panel. See the “FUSES” section for details.

CLEANING

If desired, the interior of the instrument may be cleaned using compressed air to dislodge any accumulated dust. (See the “TOP COVER REMOVAL” section for instructions on accessing the interior.) No other cleaning is recommended.

REPAIR INSTRUCTIONS

 Caution: High voltages are present inside the instrument during normal operation. Do not operate the instrument with the cover removed.

BLOWN FUSES

See the “AC FUSE REPLACEMENT” and “DC FUSE REPLACEMENT” for fuse replacement instructions.

DAMAGED MAIN OUTPUT

The integrated circuit (IC) that generates the MAIN OUTPUT signal is installed in a socket, and may be replaced if it has been damaged through improper use. (The output stage does feature protection circuitry).

To replace this IC, turn off the instrument and remove the top cover. Locate the large 24-pin IC immediately behind the MAIN OUTPUT connector. This IC has a black clip-on heatsink. The IC can be removed by gently pulling it up and out of its socket.

The following parts are suitable replacements:

<i>Manufacturer</i>	<i>Website</i>	<i>P/N</i>	<i>Production Status</i>
Cadeca	http://www.cadeca.com	KH103AI	In production.
Fairchild Semiconductor	http://www.fairchildsemi.com	KH103AI	Discontinued.
Comlinear	(bought by Fairchild)	CLC103AI	Discontinued.
Comlinear	(bought by Fairchild)	CLC103AM	Discontinued.

PERFORMANCE CHECK SHEET